

CONTENTS

1. IMPORTANT NOTES	125
1.1 NOTES ABOUT OB-12	125
1.2 NOTES ABOUT THE MANUAL	125
2. MAIN CHARACTERISTICS	126
3. CONTROLS AND CONNECTORS	127
3.1 THE FRONT PANEL	127
3.2 THE CONTROL CENTER SECTION	129
3.3 THE REAR PANEL	130
4. CONNECTIONS	131
4.1 SPEAKERS AND MONITORS	131
4.2 MIXING CONSOLE	132
4.3 MIDI UNITS	132
5. HOW TO BE OB-12 IS ORGANISED	133
5.1 MAIN STRUCTURE	133
5.2 PROGRAM, TIMBRE AND SYSTEM	135
5.3 THE AUTOMATION SECTION	138
6. PLAYING THE PROGRAMS AND TIMBRES	143
6.1 PLAY PROGRAM	143
6.2 PLAY TIMBRE	145
7. USING THE PANEL	146
7.1 SETTING THE FIRST WAVEFORM (OSC.1)	146
7.2 SETTING THE SECOND WAVEFORM (OSC.2)	148
7.3 MODIFYING THE PARAMETERS COMMON TO OSC.1 AND OSC.2 (OSC.COMMON) .	150
7.4 MODIFYING THE TIMBRE (FILTERS)	152
7.5 VOLUME CONTROL (AMPLIFIER)	155
7.6 MODULATION THE SOUND CYCLICALLY (LFO1)	156
7.7 MODULATING THE SOUND WITH THE [MODULATION] WHEEL (LFO2)	157
7.8 SETTING THE KEYBOARD (KEYBOARD)	158
7.9 ADDING EFFECTS TO THE SOUND (EFFECTS)	160
7.10 EQUALIZING THE SOUND (EQUALIZER)	161
7.11 REGULATING THE GENERAL VOLUME (VOLUME)	162
7.12 USING THE [PITCH] AND [MODULATION] WHEELS	162
7.13 ENABLING THE VELOCITY AND AFTERTOUCH	163
7.14 USING THE RIBBON CONTROLLER	163
8. EDIT TIMBRE	164
8.1 EDIT OSCILLATOR 1	165
8.2 EDIT OSCILLATOR 2	168
8.3 EDIT OSCILLATOR COMMON	171
8.4 EDIT FILTERS	173
8.5 EDIT AMPLIFIER	179
8.6 EDIT LFO1	181
8.7 EDIT LFO 2	183
8.8 EDIT KEYBOARD MODE	184

8.9 EDIT CONTROLLERS	186
8.10 WRITE TIMBRE	191
9. EDIT PROGRAM	192
9.1 EDIT PART SETTINGS	193
9.2 BUS SETTINGS	194
9.3 EDIT EFFECTS	194
9.4 EDIT EQUALIZER	199
9.5 LINKS	200
9.6 FOOT CONTROL SETUP	201
9.7 ARPEGGIO SETTINGS	204
9.8 PHRASE RECORDER	207
9.9 AUTO - MANUAL MORPH	213
9.10 KEYBOARD TRANSPOSE	214
9.11 MOTION RECORDER	215
9.12 WRITE PROGRAM	221
10. EDIT SYSTEM	222
10.1 MIDI COMMON	222
10.2 MIDI CONTROLS	225
10.3 MIDI SYNC	228
10.4 BULK DUMP	231
10.5 FOOT CONTROL SETUP	232
10.6 DIGITAL OUTPUT SETTINGS	234
10.7 GLOBAL SETUP	235
10.8 TOOLS	236
11. APPENDIX	239
11.1 SOFTWARE INSTALLATION	239
11.2 ERROR MESSAGES	240
11.3 MIDI	241
11.4 BLOCK DIAGRAM	243

1. IMPORTANT NOTES

1.1 NOTES ABOUT OB-12

LOOKING AFTER THE PRODUCT

- Do not apply excessive force to the structures and controls (knobs, switches).
- Protect the instrument from stresses both in transit and in use. The instrument should be transported in its original packaging or equivalent wrapping.
- Do not place the OB-12 close to sources of heat, in damp or dusty places or in the vicinity of strong magnetic fields.
- When possible, do not place the instrument close to units which produce strong interference such as radios, TV sets, monitors, etc...
- Do not insert foreign bodies or liquids of any kind inside the equipment.
- For cleaning, use only a soft cloth or compressed air; never use detergents, solvents or alcohol.
- Do not expose the instrument to direct sunlight.
- Do not hit the display or apply excessive force to it.

CONNECTING TO THE ELECTRICAL MAINS

- To avoid the risk of electric shock, do not make the connections with wet hands.
- Make sure that the mains voltage is as indicated on the lower panel.

CONNECTING TO OTHER INSTRUMENTS

- Always use good quality screened cables. When disconnecting cables from sockets, always take hold of the connector and not the cable itself; when coiling them, do not allow knots or twists to form.
- Before making the connections ensure that the other units (especially amplification and diffusion systems) you are about to connect are switched off. This will prevent noisy or even hazardous signal peaks.

1.2 NOTES ABOUT the MANUAL

- Take good care of this manual.
- Read all the information provided in this manual carefully. You will avoid wasting time and will obtain the best performance from your instrument.
- Codes or numbers in square brackets ([]) refer to the names of buttons, sliders or trimmers on the instrument panel.
For example, [RATE] means the RATE trimmer.
- Illustrations and display pages are for information only and may differ from those actually shown on the LCD.

2. MAIN CHARACTERISTIC

REAL-TIME CONTROL EFFECTIVENESS

The OB-12 is a synthesizer designed to be fully controllable in real time, the main feature of the famous analog synthesizers. And the huge advantage this provides is a user-friendliness which was perhaps being lost with the latest digital synthesizers, with programming procedures too complex for many people to attempt. However, this does not mean the OB-12 offers limited potential. You will realise this as you read this manual and use the instrument.

As well as giving an “analog feeling”, the OB-12, also uses the most sophisticated digital technology for signal generation and processing.

We said “analog feeling”, because the OB-12 is the natural evolution of the analog synthesizers which have shaped the history of music. Although not perfect (limited storage capacity, unstable tuning and limited polyphony) due to their analog nature itself, these synthesizers were controlled by means of a vast number of knobs which made them extremely easy to use.

With the advent of digital synthesizers, this ease of use has been lost somewhat, as all the generation controls have been shifted into software programming pages.

The OB-12 has been developed to combine this user-friendliness with the best sound generation and processing technologies. The front panel is subdivided into various sections, containing the controls dedicated to the various blocks of the generation chain.

TOTAL MEMORISATION

The OB-12 offers the user 256 Programs, all modifiable and memorisable. Each Program can contain up to 4 parts (so that you can divide the keyboard into 4 zones), each with a different timbre. In addition to this, the instrument also offers 256 Timbres, also totally modifiable and memorisable.

AUTOMATION

The OB-12 offers automated systems for the most widely varying functions. For example, you can make use of a completely configurable arpeggio and a Phrase Recorder in which you can memorise musical phrases ready for recall by pressing a keyboard key.

You can also use a Motion Recorder in which you can memorise specific motions of the panel controls, which can all be repeated at the touch of a button, and a Morphing function, enabling you to transform a sound to another and to listen to all the continuous variations as you do so.

CONTROLS

As well as the usual trimmers and buttons for control of sound generation, the OB-12 allows you to use [PITCH] and [MODULATION] wheels for real-time control of the tuning of the timbres (the first) and the depth of modulation by the LFO 2, the Morph or the parameters assigned to Aftertouch (the second).

What's more, there is also a Ribbon Controller; after assigning the various generation parameters to this controller, you can then control them by just running a finger over its surface.

3. CONTROLS and CONNECTORS

3.1 The FRONT PANEL

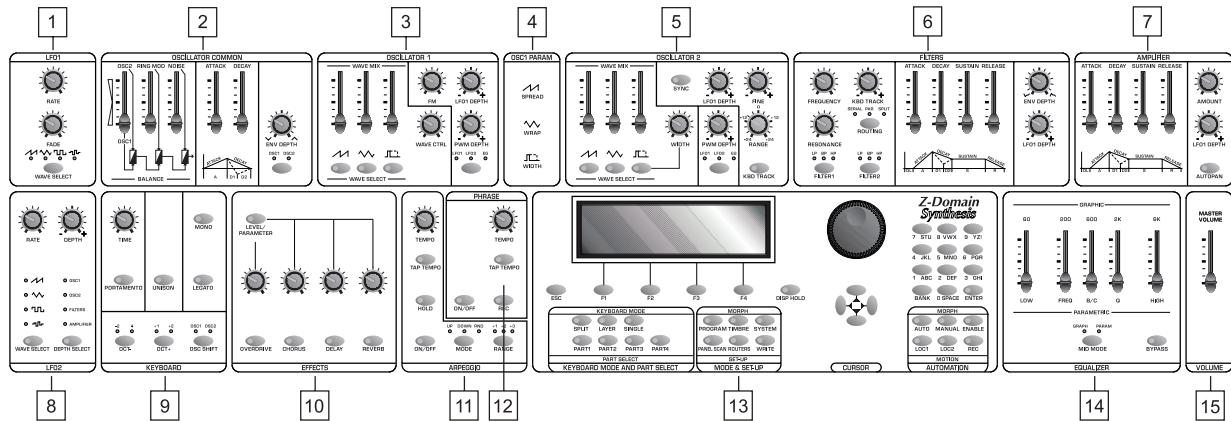

1. LFO 1 section

This section of the front panel contains the controls relating to the LFO 1 (Low Frequency Oscillator 1). The LFO 1 is the first low frequency oscillator in the generation chain, capable of generating a waveform which modulates the sound cyclically.

2. OSCILLATOR COMMON section

Here you will find the controls for the common settings of the OSCILLATOR 1 and OSCILLATOR 2 sections. These controls allow you to set the envelope of the oscillators and their balancing (since they are able to generate two different waveforms) to control the tuning of the sound.

3. OSCILLATOR 1 section

These controls allow you to set the characteristics of the first oscillator for generation of the first basic waveform (which however, will already be complex) of the sound you are about to create.

4. OSC 1 PARAM (Oscillator 1 Parameter) section

This section describes the functions of the [WAVE CTRL] control knob in the OSCILLATOR 1 section.

5. OSCILLATOR 2 section

As for the OSC 1 section, here you can set the characteristics of the second waveform which is the basis of the sound generated by the second oscillator.

6. FILTERS section

This section contains the controls relating to the characteristics (envelope, cut-off frequency and resonance, to name the most significant) of the filter, i.e. the combination of FILTER 1 and FILTER 2, by means of which you can modify the brightness of the sound over time.

7. AMPLIFIER section

Here you can set the characteristics of the amplifier used to regulate the level of the sound over time.

1. LFO 2 section

This section contains the controls relating to the settings of the second low frequency oscillator, controllable by means of the wheel on the left of the keyboard, marked [MODULATION].

2. KEYBOARD section

Here you can adjust a number of parameters relating to the keyboard, including the performance mode, enabling of the Portamento or Unison status and transposition of the oscillators by octaves.

10. EFFECTS section

Here you can enable and set the level of a parameter (assigned by means of the programming pages) of the four effects offered by the OB-12, i.e. Overdrive, Chorus, Delay and Reverb.

11. ARPEGGIO section

Here you can activate and set the basic characteristics of the function used to arpeggio chords or single notes being played on the keyboard.

12. PHRASE section

This section allows you to enable and set the PHRASE RECORDER system, used to record a musical phrase and repeat it (or play phrases already memorised) at the touch of a keyboard key.

13. CONTROL CENTER section

This section contains all the commands for display operations, for assignment of parts to the keyboard and for the MOTION and MORPH functions. See point 3.2 – CONTROL CENTER Section for further information.

14. EQUALIZER section

This section allows equalisation of the sound using an equaliser which can be configured as graphic or parametric.

15. VOLUME section

This section contains the [MASTER VOLUME] slider for control of the instrument's overall volume.

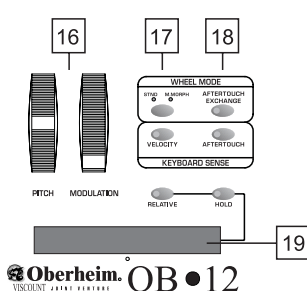

16. [PITCH] and [MODULATION] wheels

You can use the [PITCH] wheel to make various continuous adjustments to the tuning in a sharp or flat direction. The [MODULATION] wheel, on the other hand, can be used to set the quantity of signal from the LFO 2 to be used to modulate the sound, to carry out manual MORPH procedures, and to check the parameters assigned to the Aftertouch.

17. WHEEL MODE section

This section contains the controls for setting the functions of the [MODULATION] wheel.

18. KEYBOARD SENSE section

Contains the controls for enabling the Velocity and the Aftertouch.

19. Ribbon Controller

This device allows you to control various parameters by just moving a finger along its surface.

3.2 The CONTROL CENTER SECTION

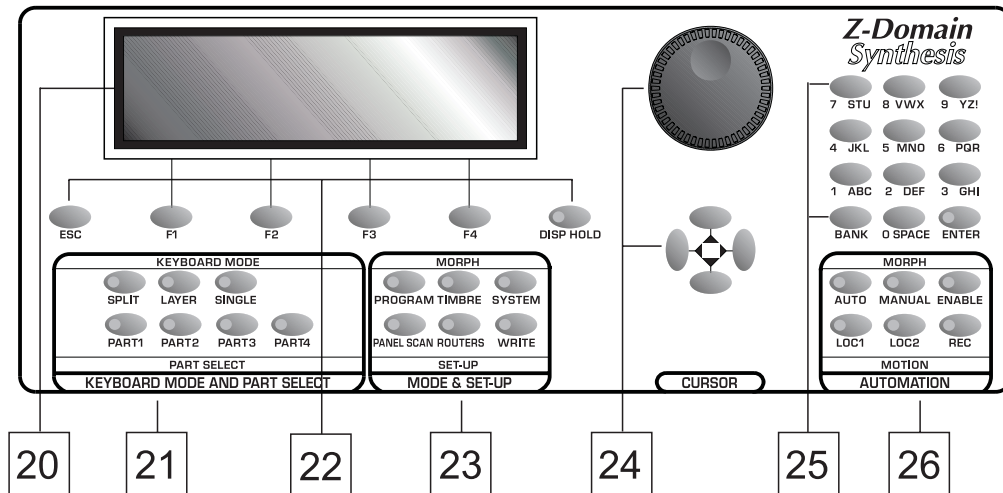

20. Display

Backlit liquid crystal display of 240 x 64 pixels for displaying the names of the Programs and Timbres, and all the functions relating to programming of the OB-12. Thanks to this generously sized display, all operations will be easier and learning about the programming parameters will be more intuitive with the aid of specific bitmap or calculated graphic references.

21. KEYBOARD MODE AND PART SELECT section

In this section, you can set the procedure for assigning Parts to the keyboard. Using the [SPLIT] button the Parts active in the Program will play in separate sections of the keyboard (defined by the keyboard range assigned to them), while with the [LAYER] button the active Parts can be played along the entire keyboard. The [SINGLE] button enables only the Part whose LED associated to one of the [PART] buttons is illuminated.

The [PART1] - [PART2] - [PART3] - [PART4] buttons allow you to activate the part of your choice (when playing in SINGLE mode) and display and/or edit the timbre associated to it.

22. Buttons for display operations

This group of buttons includes an [ESC] key for exiting from the video page or the function currently shown on the display. Four buttons [F1] - [F2] - [F3] - [F4] are provided for selecting pages in addition to the one displayed at that moment, and for enabling any functions shown on the display in line with the button concerned. There is also a [DISP HOLD] (Display Hold) button used when the Swapping function is active; this function allows immediate display of a video page relating to a parameter which has been modified using the relative control on the panel, and the Display Hold button allows the new page to be kept on the screen, preventing the return to the previous video page.

23. MODE & SET-UP section

You can use the [PROGRAM] - [TIMBRE] - [SYSTEM] buttons to select the operating environments of the same names. The [PANEL SCAN] button allows you to set the programming parameters in accordance with the values assumed by the controls on the panel when the button is pressed. The [EFFECTS] key recalls the menu for connection of the effects and the [WRITE] key enables the procedures for saving Programs or Timbres, depending on the operating environment active.

N.B.: Modifications made to the fields present in the SYSTEM environment are saved automatically.

24. Rotary encoder and [CURSOR] keys

The rotary dynamic Encoder allows you to select the Program or Timbre of your choice, to increase or decrease the value of the parameter currently selected or to position the cursor on the chosen field in the option selection menu (e.g. in the Edit Program Menu). The [CURSOR] keys provide the same cursor positioning function.

25. Number keypad

Number keypad for entering the values of parameters or for typing the names of Programs and Timbres during saving operations. You will press the [ENTER] button to confirm settings made or to start procedures when the system prompts this. There is also a [BANK] button for selecting the Program or Timbre memory bank, and + and – signs for entering number values where negative and positive values are present.

26. AUTOMATION section

This section actually contains two different functions. The first relates to the Morph, meaning the possibility of passing from one Program or Timbre to another in a programmable period of time or using the [MODULATION] wheel, while the second relates to the Motion, or two memory locations in which all the movements carried out on the panel controls over a given period of time can be recorded. You can use [AUTO] and [MANUAL] buttons to recall the automatic or manual Morph functions, while the [ENABLE] key allows you to start the procedure concerned.

The [LOC1] and [LOC2] can be used to recall one of the two Motion Locations, while the [REC] key enables recording of the movements of the panel controls.

3.3 The REAR PANEL

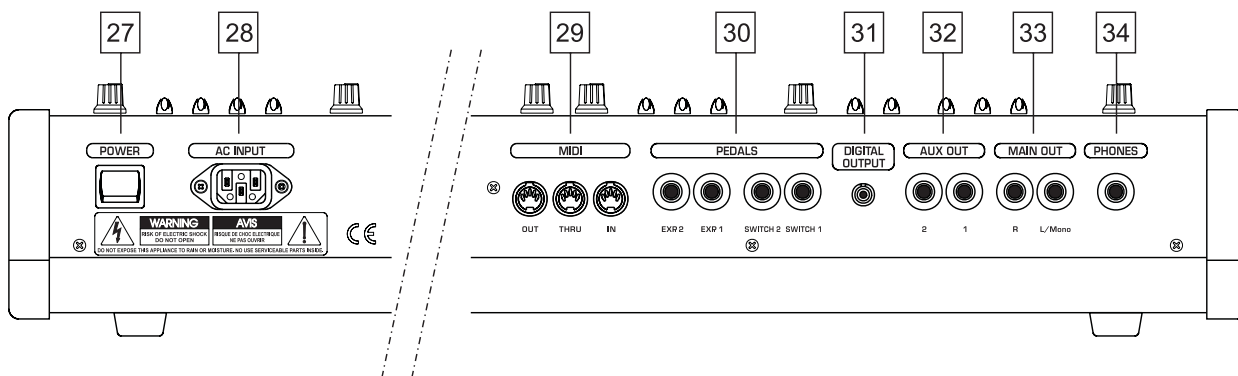

27. [POWER] switch

Switch used for turning the OB-12 on and off.

28. [AC INPUT] connector

Connect the power supply lead provided with the instrument to this connector.

29. MIDI connectors

Connect the MIDI units you wish to use together with the OB-12 to these connectors. The MIDI [OUT] connector sends the MIDI messages generated by the OB-12, while the MIDI [THRU] connector sends the MIDI codes received by the MIDI [IN] port, i.e. the input port for MIDI messages generated by a remote MIDI unit.

30. PEDALS connector

Connect the leads from remote pedals to which you have assigned functions by means of the

internal programming parameters to these connectors. Connect expression pedals to the [EXP.1] (Expression 1) and [EXP.2] (Expression 2) connectors, and footswitch pedals to the [SWITCH1] and [SWITCH2] ports.

31. [DIGITAL OUTPUT] connector

You can use this socket to collect the digital signal generated by the OB-12 in order to connect the instrument to DATs, digital mixers, CD mastering units, etc..

32. AUX OUT connectors

Extra connectors from which the analog signal generated by the OB-12 can be collected.

33. MAIN OUT connectors

Main connectors from which the analog stereophonic signal produced by the OB-12 can be collected. If you are using a monophonic unit for amplifying or recording the signal, connect the [L/MONO] connector only.

34. PHONES connector

You can connect a set of headphones to this connector in order to monitor the sound of the OB-12 without the aid of amplified monitors. The signal will still be present at the [MAIN] and [AUX] outputs.

4. CONNECTIONS

4.1 SPEAKERS and MONITORS

The output signal at the MAIN OUT [L/MONO] and [R], AUX OUT [1] and [2] connectors is not amplified. In order to listen to the sound produced by the OB-12, you will have to connect the connectors to remote amplifiers or to amplified speakers/monitors. It is also advisable always to use a stereophonic system, to allow you to appreciate the sound and effects generated by the OB-12 to the full.

In addition, the instrument offers the considerable advantages of the BUS SETTINGS function in the PROGRAM environment, allowing each single part of a Program to be assigned to each individual output, thus assuring spectacular acoustic effects. For example, if each of the four Parts of a Program contains a different timbre and each single part is assigned to each single output, you will be able to listen to each timbre by means of a different diffuser or monitor.

You will also be able to address the signal present on the MAIN OUT outputs to amplified diffusers, and to listen to the signal present on the AUX OUT outputs by means of a monitor. Instead of the monitor, you can also listen to your sound on headphones, by taking the signal from the [PHONES] connector.

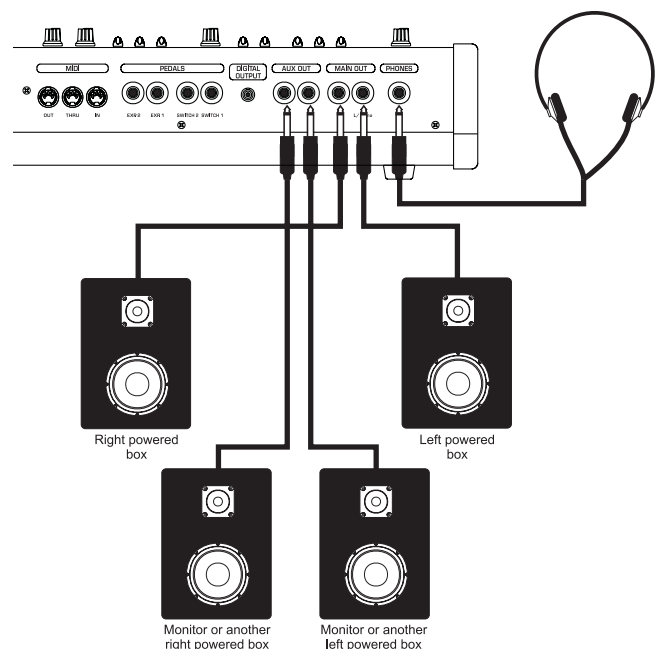

4.2 MIXING CONSOLE

Connecting the OB-12 to a mixing console will allow you to obtain excellent advantages, with the possibility of using four outputs. For example, you can address the MAIN OUT connectors to two channels (or to one stereo channel) and the AUX OUT connectors to two different channels, so that the signals on the outputs can be processed differently. This solution is especially useful when, for example, you wish to process the individual Parts of a Program differently from each other.

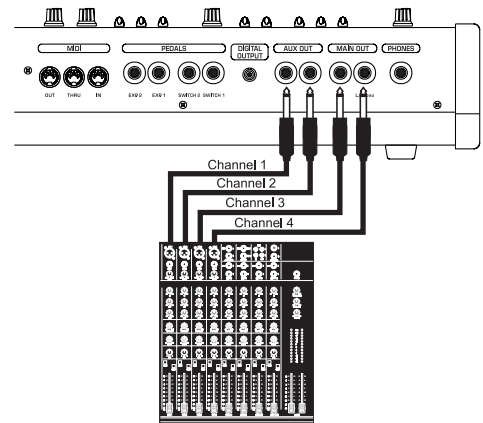

4.3 MIDI UNITS

The OB-12 can be MIDI-connected to Master Keyboards, Sequencers, another synthesizer, or a Personal Computer MIDI interface, thus allowing the use of the most sophisticated musical softwares (writing of scores, saving and editing of musical patterns, real time controls by PC of the OB-12 internal parameters, etc.).

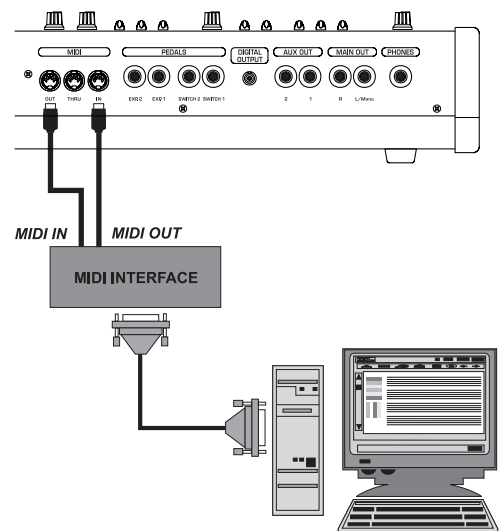

5. HOW TO BE OB-12 IS ORGANISED

5.1 MAIN STRUCTURE

Essentially, the OB-12 consists of five main sections:

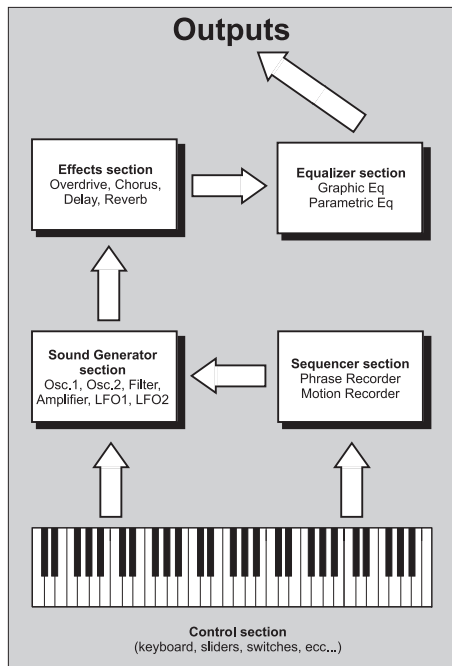

CONTROL SECTION

The *control section* consists of the velocity and Aftertouch sensitive 49-key keyboard and the controls on the panel. If the OB-12 is piloted by a Master Keyboard (or by another MIDI controller), the *control section* is also assumed by the connected MIDI devices.

Whenever you press a keyboard key or a button (for example) on the control panel, a message is sent to the *sound generation section*, or to the *sequencer section* in case of use of the Phrase Recorder and/or the Motion Recorder.

SOUND GENERATION SECTION

This section of the OB-12 generates the sound you program using the panel controls or the display. The data received from the *control section*, from the *sequencer section* in case of playback of Phrases or Motions, or from the [MIDI IN] port in case of connected MIDI units, inform the *sound generation section* of how and when it is to produce the sounds, and on what time-scale.

The OB-12 has maximum polyphony of 12 notes, meaning that it is able to produce a maximum of 12 notes simultaneously. If the *control section* sends data for a larger number of notes, the last notes received by the *sound generation section* will take priority, while the first ones will be gradually deactivated as subsequent notes are received. Remember this during your performances.

EFFECTS SECTION

You can use this section to add four effects (which can all be used indiscriminately) to the signal sent by the *sound generation section*. These effects, all typical of the sound of the best synthesizers, are Overdrive (to add distortion), Chorus (to add space to the sound), Delay (echoes or delays on the original sound) and Reverb (reverberation of the sound).

EQUALIZER SECTION

This section allows you to make use of a totally programmable equalizer. The main feature of the OB-12 equalizer is that it can be configured in parametric or graphic mode. Using the graphic equalizer, you can regulate the high and low frequencies and medium frequency bands which can be set with the trigger frequency, band width and enhancement/attenuation value of your choice. The graphic equalizer allows you to work on five preset frequency bands.

SEQUENCER SECTION

This section allows you to record a keyboard performance (Phrase Recorder) or the movements carried out on the panel controls (Motion Recorder) in the form of MIDI data. During playback, the *sequencer section* will send the MIDI data to the *sound generation section*, which will generate the sounds. The MIDI data can also be sent during playback to remote MIDI units, by means of the [MIDI OUT] connector, allowing the sound to be generated by means of these units.

HOW DOES THE OB-12 PRODUCE THE SOUND?

In theory a sound (whether an imitation of an acoustic instrument or a completely new, “surreal” sound) can be generated with the aid of just three fundamental circuits:

- an oscillator: to generate the basic waveform and control its pitch
- a filter: to control the character of the sound
- an amplifier: to control the volume

In order to render the signal produced by these three components variable over time, envelope generators are used: they specify how the signal is to change over time.

We will therefore have one envelope dedicated to the oscillator, to determine how the pitch will change over time, one envelope dedicated to the filter, to determine how the brightness will change over time, and one envelope dedicated to the amplifier to regulate the volume over time.

At a later point, when we discuss editing of a timber (section 8), we will describe the various sections of a synthesizer in greater detail.

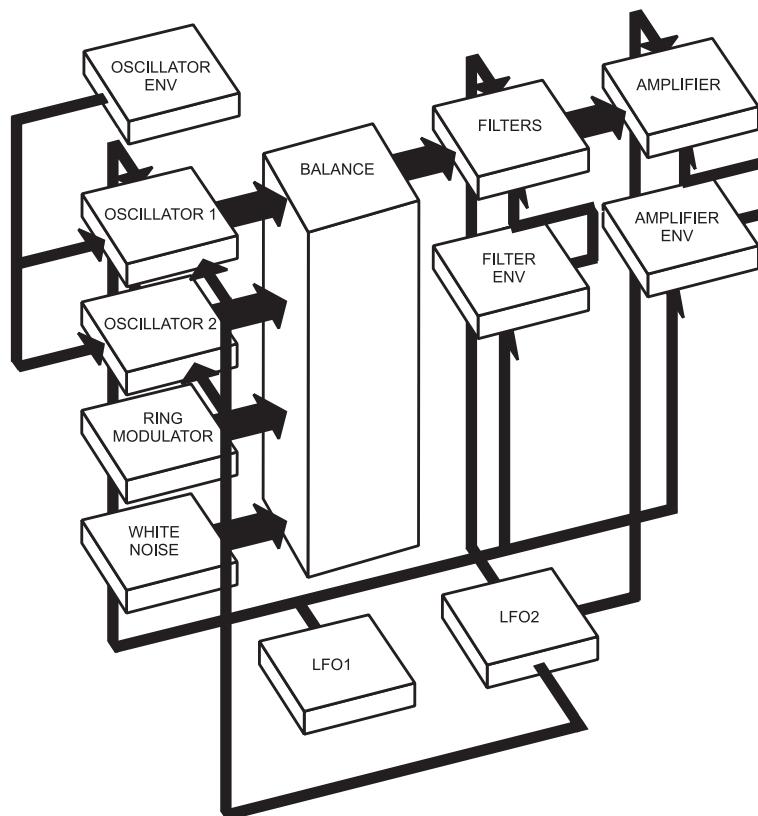

When generating sound, the OB-12 emulates the **subtractive synthesis** technique, without a doubt the most widely used in the old but still effective analog synthesizers.

With this type of synthesis, the timbre is created by generating a waveform with a high harmonics content, which is then filtered to attenuate the unwanted harmonics. The resulting sound is sent to the amplifier in order to control its width. These filtering and amplification processes will provide the sound required.

5.2 PROGRAM, TIMBRE and SYSTEM

The internal memory is mainly subdivided into four large sections:

1. the memory section reserved for the PROGRAMS (and thus the PROGRAM operating environment)
2. the memory section reserved for the TIMBRES (TIMBRE operating environment)
3. the memory section reserved for the SYSTEM UTILITIES (SYSTEM operating environment)
4. the AUTOMATION section, comprising the ARPEGGIO, PHRASE RECORDER and MOTION RECORDER functions.

We will now take a detailed look at the first three sections.

THE PROGRAMS

The OB-12 contains 256 Programs, 128 in bank A and 128 in bank B, completely programmable and all memorisable.

A Program can be set with up to four Parts containing one Timbre each, and offers the possibility of configuration with four different timbres. Naturally, this example is purely guideline, since it is not always necessary to set a Program with four parts and thus with four different timbres.

As well as containing the Timbres, the Program also allows the addition of effects and equalization of the sound generated by the timbres, regulation and performance of arpeggios, configuration of the outputs, and other useful functions which we will be looking at later.

Refer to section 9 of this manual for all necessary information about the Programs. In addition, section 7 describes the panel controls of the sections associated to the Programs (Effects, Arpeggio, Phrase Recorder and Equalizer).

You can access the PROGRAM operating environment (which is also preselected when the instrument is switched on) by pressing the [PROGRAM] button in the MODE&SET-UP section of the central panel. Once the selection has been made, the LED of the key illuminates and the following video page appears in confirmation:



THE TIMBRES

A Timbre is the basis of the sound you produce using the Program. However, while you cannot play a Program unless it contains at least one Timbre, the Timbre itself can be played on its own, regardless of the Program settings, by enabling the Timbre operating environment.

The OB-12 memory contains 256 Timbres, 128 in bank A and 128 in bank B. The internal structure of the Timbre is essentially as shown below:

As the diagram in the next page shows, this generation chain consists of four main components:

- OSC.1 and OSC.2: which generate the two waveforms (which as we will see, can be the result of three signals for each oscillator);
- FILTERS: programmable combination of two filters which attenuate the unwanted harmonics of the signals produced by the oscillators, and thus control the brightness of the sound;
- AMPLIFIER: which controls the level of the signal leaving the filters:

and then by a further five sections which control the four main ones:

- OSC ENV: which acts on the oscillators and establishes their behaviour over time, and thus defines how the pitch will change over time;
- FILTER ENV: which sets how the filters will behave over time and thus how the character of the sound will change over time;
- AMP ENV: which regulates the behaviour of the amplifier and thus determines how the volume will change over time;
- LFO1: low frequency oscillator used to modulate the signal (when required) on the four main components;
- LFO2: like LFO1 but controllable using the [MODULATION] wheel.

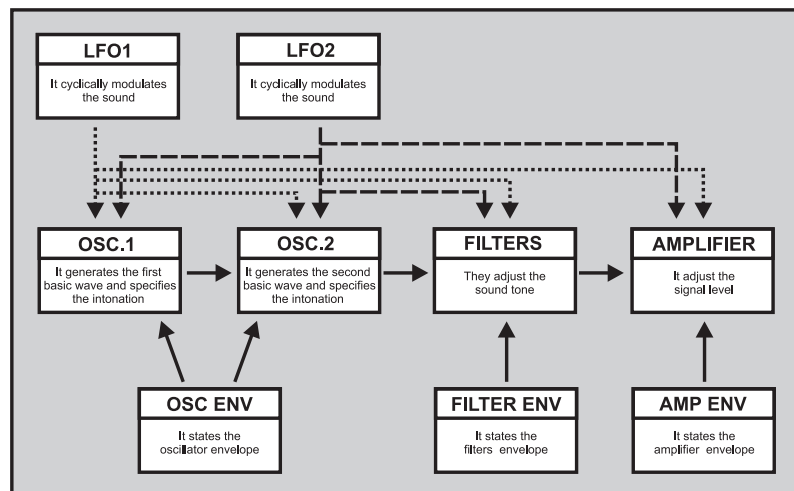

In the Timbre operating environment, the user can set up the keyboard modes and pitch, and the dynamic (Velocity) and Aftertouch controls.

Section 7 of the manual illustrates all the panel controls relating to the Timbre settings. Section 8 contains all the display settings relating to the Timbre operating environment.

To access this operating environment, press the [TIMBRE] key in the MODE&SET-UP section of the central panel. Once the selection has been made, the LED of the key illuminates and the following video page appears in confirmation:



THE SYSTEM

The SYSTEM operating environment allows the user to make use of all the utility functions which are not essential for the purposes of the generation and diffusion of the sound, but which allow configuration of the whole system (and therefore not of the individual Programs or Timbres) to individual requirements.

These utilities include all settings on the MIDI (mode, filters, MIDI Program Map, assignment of Control Changes to the controls, synchronisation, data Bulk Dump), assignment of functions to the pedals, setup of the digital output, display contrast, swapping, etc.

Refer to section 10 of the manual for all information concerning the System operating environment.

To access this operating environment, press the [SYSTEM] button in the MODE&SET-UP section of the central panel. Once the selection has been made, the LED of the key illuminates and the following video page appears in confirmation:

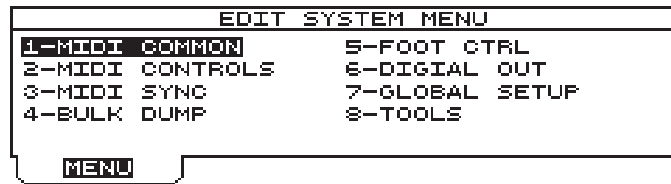

THE DISPLAY SWAPPING FUNCTION

As we will see below, the OB-12 has a huge number of parameters and controls on the front panel, used to generate the type of sound desired. It may often occur that when the Play Program video page is displayed (i.e. not the Program editing video pages) the user wishes to modify a given control on the panel, and check the value associated to it, without switching from the Program to the Timbre operating environment for the purpose. At other times, it may useful to display a timbre editing page immediately by just moving a control on the panel, without having to carry out the entire display procedure to obtain display of the video page concerned.

The DISPLAY SWAPPING function allows the user to display a given menu page by just changing the position of a control whose parameter is present in the video page. This means that the video page can be displayed momentarily (to check the value of the parameter whose panel control is being used) or the user can “freeze” it and then move around the menus relating to the video page displayed by simply pressing the [DISP HOLD] (Display Hold) button in the Control Center section of the front panel.

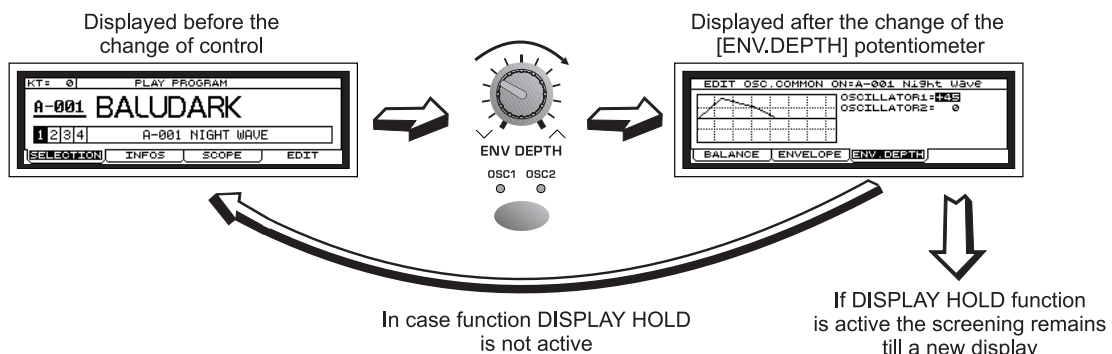

The OB-12 also allows the user to set the Display Swapping function to his own requirements, in order to obtain the best from this important, useful function.

After pressing the [SYSTEM] button, select option 7-GLOBAL SETUP. The display will show:



now select the SWAPPING folder to access the function set-up:

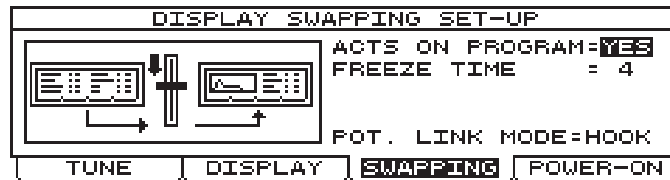

which contains the following settings:

- **ACTS ON PROGRAM:** use this parameter to enable the function in Play Program mode (but not in Edit Program mode).
- **FREEZE TIME:** here you can set the time for which the video page is to remain on the display before the display again shows the video page present before the Swap (provided the DISPLAY HOLD is not active).
- **POT. LINK MODE** (*Potentiometer Link Mode*): specifies whether the user wishes to set the parameter immediately with the value assumed by the control on the panel (by selecting HOOK) or to wait until the control assumes the value shown on the display (by selecting VALUE) and then proceed to modify the parameter.

Refer to point 10.7 for further information about setting the function.

5.3 The AUTOMATION SECTION

The term AUTOMATION refers to the section in the OB-12 which allows the performance of automatic operations triggered using the special controls on the front panel. As well as controlling the start of the automation, this section allows the user to set and personalise it both using the display and by means of the panel controls.

The AUTOMATION section is subdivided into two large categories:

- the NOTE automation functions;
- the GENERATION automation functions.

The note automation functions include the ARPEGGIO and PHRASE RECORDER functions, while those relating to generation are the MOTION RECORDER and MORPH functions.

We will now take a detailed look at these four functions.

ARPEGGIO

By means of this function, the OB-12 allows you to perform arpeggios by just playing a note or a chord on the keyboard. You can set the mode, time and playing pattern of the arpeggio, the range in octaves and the synchronisation with a remote MIDI unit. The ARPEGGIO function belongs to the Automation memory section, but it is correlated to the Program environment, so it is possible to have one type of arpeggio for each program.

Refer to point 9.6 – Arpeggio Settings for further information about this function.

The front panel section dedicated to the arpeggio comprise the following controls:

- **[TEMPO]:** this trimmer regulates the metronome tempo for performance of the arpeggio. The range of values is from 25 BPM (Beats Per Minute) with the trimmer turned completely to the left to 250 BPM (trimmer turned completely to the right).

- **[TAP TEMPO]**: this button allows you to set the metronome tempo of the arpeggio by pressing the button itself. The LED on the button displays the current metronome tempo, and if the key is pressed twice, the OB-12 will calculate the time between one press and the next in order to set the arpeggio tempo. If a remote MIDI CLOCK source is connected the value of this parameter will be that specified by the MIDI message. Any manual settings will be ignored.
- **[HOLD]**: this button allows the user to enable the HOLD function, by means of which the OB-12 will perform the arpeggio even after the keyboard keys have been released. With the function disabled, when the keyboard keys are released the arpeggio will cease. The button LED displays the status of the function in accordance with the following rule:

- LED on: function active
- LED off: function disabled

With the function active, if another note or another chord is played after the one on which the instrument is playing the arpeggio, the new notes will replace the ones on which the arpeggio was previously based.

- **[ON/OFF]**: button for enabling or disabling the Arpeggio function. The button LED displays the status of the function in accordance with the following rule:
- LED on: function active
 - LED off: function disabled

If this button is pressed for at least two seconds, the Arpeggio setting video page will be displayed.

- **[MODE]**: this button allows selection of the arpeggio mode. The settings available are:
- **UP**: the arpeggio is performed cyclically from the lowest to the highest note.



- **DOWN**: the arpeggio is performed cyclically from the highest to the lowest note.



- **UP & DOWN** (UP and DOWN LEDs on): the arpeggio is performed cyclically from the lowest to the highest note and vice-versa.

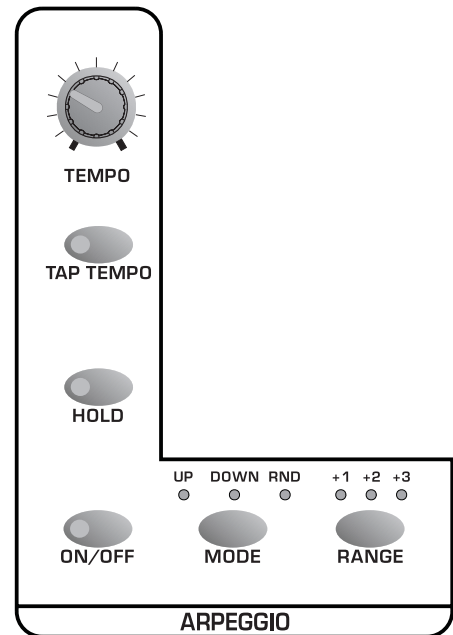



- **RANDOM** (RND): the arpeggio notes are played at random.



- **[RANGE]**: this button allows you to set the range in octaves of the arpeggio. The ranges available are:
 - **+1**: arpeggio range two octaves.
 - **+2**: arpeggio range three octaves.
 - **+3**: arpeggio range four octaves.
 - **no LED on**: the range of the arpeggio is limited to the notes played. If just one note is played, no arpeggio will be performed; the note itself will simply be repeated.

THE PHRASE RECORDER

The PHRASE RECORDER is another automated function. Using this function, once a keyboard key (pilot key) is pressed, the OB-12 performs a musical phrase recorded previously, continuing to play it in a loop until the key concerned is released (provided the HOLD function is not active). The OB-12 allows recording of up to four Sets of musical phrases, each with maximum capacity of 16000 notes and minimum resolution of 96 t.p.q.n.

The MIDI data relating to the Phrase being played will be transmitted on the MIDI [OUT] port (except for any filters enabled for the note messages).

Point 9.7 describes all the display procedures relating to this function.

N.B.: The ARPEGGIO and PHRASE RECORDER automation functions are mutually exclusive, so if the Arpeggio is active and the Phrase Recorder is selected the former is disabled, and vice-versa.

The panel section dedicated to the Phrase Recorder comprise the following controls:

- **[TEMPO]**: this trimmer allows you to regulate the metronome tempo for performance of the arpeggio. The range of values is from 25 BPM (Beats Per Minute) with the trimmer turned completely to the left to 250 BPM, with the trimmer turned completely to the right.
- **[TAP TEMPO]**: as for the Arpeggio, this button allows you to set the metronome tempo for performance of the musical sequence. The LED on the button displays the current metronome tempo, and if the key is pressed twice, the OB-12 will calculate the time between one press and the next in order to set the tempo for performance of the musical phrase. If a remote MIDI CLOCK source is connected the value of this parameter will be that specified by the MIDI message. Any manual settings will be ignored.

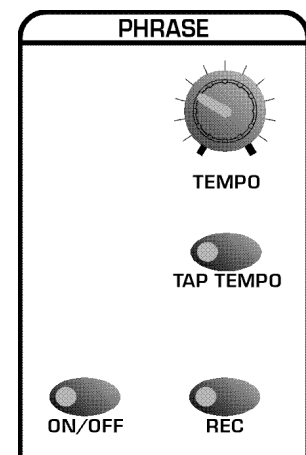

- **[ON/OFF]**: this button allows you to activate or deactivate the Phrase Recorder function. The status of the function will be displayed by the LED on the button concerned in accordance with the following rule:

- LED on: function active
- LED off: function disabled

When the button is kept pressed for at least two seconds, the display will show the video page containing the parameters for performance of the phrases.

- **[REC]**: this key enables the Record Phrase function, used to record a musical phrase. An Event Editor is also available for displaying and modifying the data contained in a Phrase. When the key is pressed, the LED illuminates and the OB-12 presets for recording of the musical sequence, showing the video pages for the function on the display.
- **[HOLD]** (of the ARPEGGIO section): this button provides the same function as for the ARPEGGIO automation function. The LED displays the function status following the usual rule:

- LED on: function active
- LED off: function disabled

When this function is enabled, the musical phrase the OB-12 is playing will continue to be performed even when the keyboard key enabled to Start the Phrase (pilot key) is released. When another pilot key is pressed, the phrase associated to it will be played instead of the previous one.

THE MOTION RECORDER

The MOTION RECORDER function allows the user to record and repeat movements of trimmers or sliders on the OB-12 front panel. This enables you to vary the sound continuously without moving the controls on the panel.

The data relating to the movements of the controls on the panel can be recorded in two memory locations (Motion Location 1 and Motion Location 2) independent from the Program; each of them is able to contain two minutes of recording, i.e. 16000 events with resolution of 96 t.p.q.n. Refer to point 9.10 for further information relating to this function.

The panel selection relative to this automated function containing the commands:

- **[LOC 1]**: this button is pressed to start the sequence recorded in Motion Location 1. The LED of the key concerned will illuminate and remain constantly on, with a small break at the end of each loop. When the key is pressed again, the repetition will stop and the LED will go out.
- **[LOC 2]**: this button is pressed to start the sequence recorded in Motion Location 2. The LED of the key concerned will illuminate and remain constantly on, with a small break at the end of each loop. When the key is pressed again, the repetition will stop and the LED will go out.
- **[REC]**: this button is pressed to start the recording (Record Motion) procedure, or the procedure for displaying or modifying the events contained in a Motion (Motion Event Editor), with display of the pages relating to the procedures and the recording parameters.

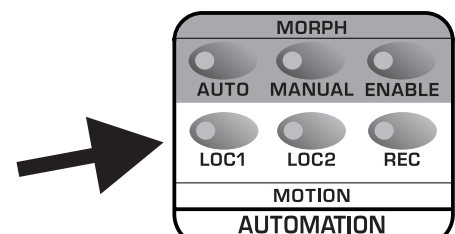

The PHRASE RECORDER section [TEMPO] trimmer and [TAP TEMPO] button can be used to regulate the metronome tempo for repetition of the Motion. If the Phrase Recorder is already active, the Motion repetition tempo will be affected by the values set for the Phrase Recorder.

THE MORPH

You can use the MORPH automated function to move from a starting Program to another (destination) Program in a period of time which can be programmed or controlled using the [MODULATION] wheel, during which all the parameters which differ in the two Programs are interpolated (i.e. varied continuously).

Point 9.8 of this manual describes all the display procedures for programming this function.

To Morph Programs or Timbres, simply select the operating environment associated to them by pressing the [PROGRAM] and [TIMBRE] buttons in the front panel MODE&SET-UP section.

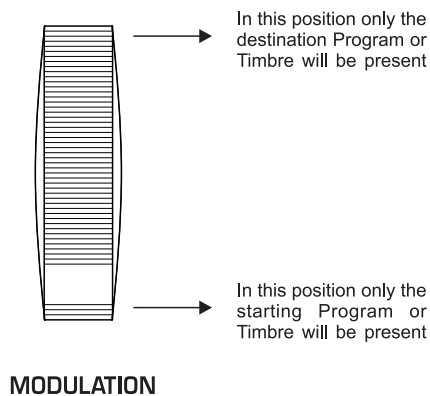

The Morph section comprises three buttons:

- **[AUTO]:** button used to enable the automatic Morph, which will be displayed by illumination of the button LED. When the relative key is pressed again, the function is disabled and the LED goes out.
- **[MANUAL]:** button used to enable the manual Morph function; the button LED then illuminates to display the selection made. Pressing the button again disables the automatic function and the LED goes out.
- **[ENABLE]:** key pressed to start the Morph function (automatic or manual). Pressing the button again will interrupt or restart the Morph.

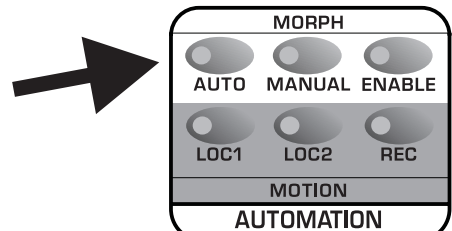

N.B.: If no manual or automatic Morphs have been selected, pressing the [ENABLE] button has no effect.

6. PLAYING the PROGRAMS and TIMBRES

Once the connections have been made, follow these simple rules to switch on the instrument, in order to prevent malfunctions and/or damage to the OB-12 and the connected instruments:

- Check that the OB-12 is correctly connected to the rest of the system.
- Check that the amplification and diffusion systems are switched off.
- Set the OB-12 volume ([MASTER VOLUME] trimmer) at the minimum level.
- Turn on the instrument using the [POWER] switch.
- Turn on the amplification system and the diffusion system.

6.1 PLAY PROGRAM

After the OB-12 has been switched on using the [POWER] switch, the display will show the presentation video pages for a few moments, after which the Play Program video page will be activated:

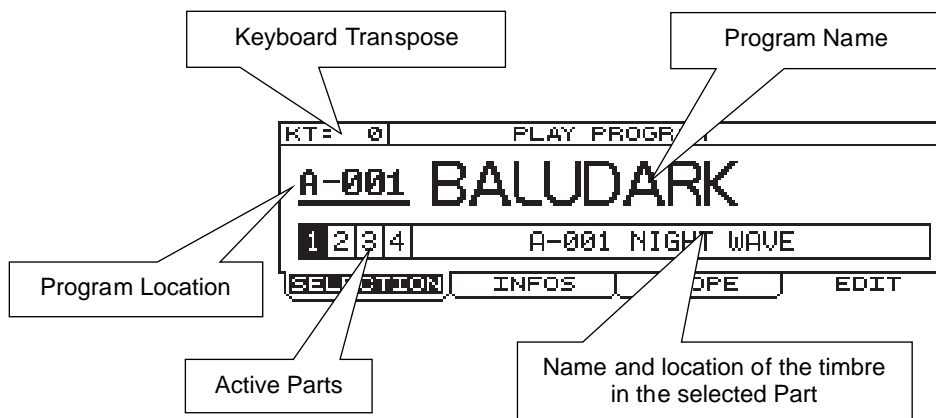

As can be seen above, this video page displays the name and memory location of the Program, the keyboard transposition (KT: Keyboard Transpose field), the Parts enabled and the Timbre contained in the Part currently selected (shown in reverse in the display field enabled for display of the active Parts: Part 1, for example, in the illustration). Whenever you wish to display this video page, press the [PROGRAM] key in the MODE&SET-UP section.

You can then scroll through all the 256 Programs using the encoder or the number keypad (in which you can also use the [BANK] key to select the memory bank), confirming with [ENTER] if you use the second option.

You can also use the [PART1] - [PART2] - [PART3] - [PART4] buttons to show on the display which Timbre is contained in the Part concerned and modify all the parameters relating to the selected Part. If one of these buttons is pressed when its Part is not selected (in the Part Settings video page) no selection will be made.

N.B.: In view of its function, if the KEYB.MODE function is set as SINGLE in the Program currently in use, pressing one of the [PART] keys will change the timbre being played as well as displaying the Timbre contained in the Part concerned.

As the above illustration shows, the video page contains three folders called SELECTION, INFOS and SCOPE, plus an EDIT field displaying a function. The folder currently selected is SELECTION, since it is open and its contents are shown in reverse. The function buttons beneath the display can be used to select the folder or function in line with the button concerned. Therefore, in this video page you can select SELECTION with button [F1], INFOS with button [F2], SCOPE with [F3] and EDIT with [F4].

Use the [CURSOR] keys to select the options in the video pages, and modify them with the encoder or the number keypad. In video pages which do not contain any parameters whose values can be modified (such as the Edit Program Menu video page), you can use the encoder (as well as the [CURSOR] keys) to select the options displayed.

Another rule to be noted is that while the folders display the current page and additional pages of the same menu, the options not contained in a folder correspond to operations. For example, EDIT means editing, CLEAR delete, GO! proceed, etc...

These rules apply to all video pages shown on the display. Refer to them for all the video pages described in the manual.

Now select the INFOS folder; the display will show:



This video page contains the main information about the Program, i.e.:

- **P (Part)**: displays the part for which the information is being displayed and the timbre associated to the part concerned. The [PART] button can be used to select the part required.
- **L (Level)**: the level of the Timbre contained in the Part concerned.
- **O (Output)**: the rear panel outputs associated to the Part.

In addition, the display shows the keyboard range of the Parts in the Program; the line of the selected Part is thicker and the keyboard keys associated to the Part are in reverse.

Now select the SCOPE folder and the display will change to:

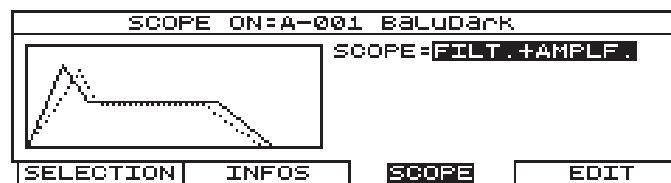

You can use the SCOPE parameter, controlled by means of the encoder or the number keypad, to display:

- **FILTER**: the envelope of the filters in the Timbre currently active.
- **AMPLIFIER**: the envelope of the amplifier present in the Timbre currently active.
- **FIITER+AMPLIFIER**: the overlapped envelopes of the filters and the amplifier.
- **OSCILLATOR1**: the sum of the waveforms generated by the first oscillator present in the Timbre contained in the Part currently active.
- **OSCILLATOR2**: the sum of the waveforms generated by the second oscillator present in the Timbre contained in the Part currently active.

6.2 PLAY TIMBRE

As well as playing an entire Program, the OB-12 also allows the user to play the Timbres individually. From any video page, press the [TIMBRE] button in the MODE&SET-UP section of the central panel; the system will leave the Program environment and enable the Timbre present in the Part currently selected. As you will see in the KEYBOARD MODE & PART SELECT section of the central panel, the keyboard mode will be set as SINGLE (the LED of the [SINGLE] key illuminates) since the selected timbre will be present throughout the keyboard range. The display will then show the Play Timbre video page:

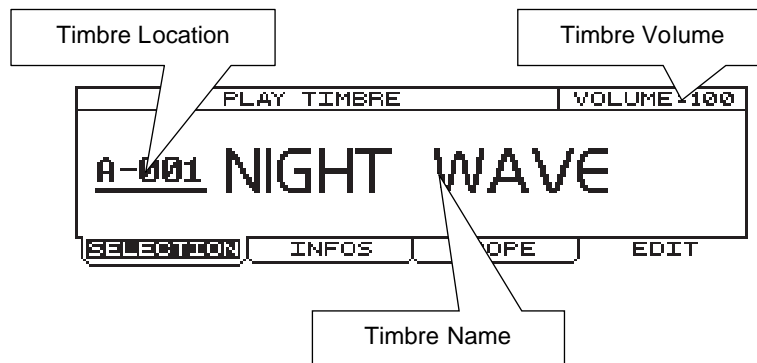

As well as the name of the Timbre and the location in which it is memorised, the display also shows its volume. After locating the cursor on this field, the encoder or number keypad can be used using the usual procedures to enter the desired value.

You can use the [PART] buttons to recall and edit the Timbres contained in the selected part.

As for the Play Program video page, this page also consists of three folders called SELECTION, INFOS and SCOPE, plus the EDIT function field.

Now select the INFOS folder; the display will show:

INFOS ON=A-001 NIGHT WAVE			
VEL.STATUS	=ON	VEL.TYPE	=LINEAR
P.B.STATUS	=ON	P.B.COURSE	=12
AFTER.STATUS	=OFF	MODUL.STATUS	=ON
KEYB.MODE	=LEGATO		
RIB.1TO=LFO1 RATE		RIB.2TO=FILT. FREQ	
SELECTION	INFOS	SCOPE	EDIT

This video page shows the status of the main system controllers with the following fields:

- **VEL.STATUS** (*Velocity Status*): informs the user whether or not the keyboard velocity control is active.
- **VEL.TYPE** (*Velocity Type*): displays the type of velocity selected.
- **P.B.STATUS** (*Pitch Bender Status*): informs the user whether the [PITCH] wheel is active.
- **P.B.COURSE** (*Pitch Bender Course*): displays the range of values controlled by means of the [PITCH] wheel.
- **AFTER.STATUS** (*Aftertouch Status*): displays whether the Aftertouch is active.
- **MODUL.STATUS** (*Modulation Status*): informs the user whether the [MODULATION] wheel is active.
- **KEYB.MODE** (*Keyboard Mode*): displays the mode of use of the keyboard.
- **RIB.1TO** (*Ribbon 1 To*): displays the first parameter controlled by the Ribbon Controller.
- **RIB.2TO** (*Ribbon 2 To*): displays the second parameter controlled by the Ribbon Controller.

The video page recalled using the SCOPE folder is identical to the video page of the same name in the PROGRAM operating environment, the meaning of which has already been explained in point 6.1; refer to this for the information required.

7. USING the PANEL

Using the panel, allowing real time modifications, is one of the main features of the best synthesizers. For this reason, we will first describe all the functions which can be recalled using the controls on the front panel.

Points 7.1 to 7.7 illustrate the sections used to edit the Timbre to create the desired sound. Points 7.8 to 7.15 describe the sections relating to additional functions, such as added effects, equalization, using the wheels and the Ribbon Controller, etc., which are also placed on the front panel since they are just as important as the functions described in the previous points.

7.1 SETTING the FIRST WAVEFORM (OSC.1)

As we have already seen in our illustration of the OB-12 main structure, the oscillator supplies the basic waveform for creation of the sound desired.

The OB-12 oscillators (Oscillator 1 and Oscillator 2) are able to generate a sound using three main waveforms, which are:

- a sawtooth waveform (or ramp).
- a triangular waveform;
- a square waveform (or pulse);

using the panel controls on the display, you can mix (or delete) the three waveforms to allow you to obtain the solution you require.

We will now take a look at the controls on the panel.

- **[WAVE MIX]:** you can use these three sliders to mix the three waveforms which will then form the output of the first oscillator. As described on the panel, the first slider controls the level of the sawtooth waveform, the second controls the triangular waveform and the third the square waveform.
- **[WAVE SELECT]:** you can use these keys to activate/deactivate the waveform associated to them. The LEDs above the keys display the status of the waveform according to the following rule:

- LED on: waveform present
- LED off: waveform deactivated

- **[WAVE CTRL]** (*Wave Control*): this trimmer regulates the second parameter (i.e. in addition to the level, controlled by the sliders) relating to the waveform currently selected. The parameter-control correspondence is described in the OSC1 PARAM section. To hook this control to the waveform parameter of your choice, press the relative [WAVE SELECT] button or move the slider related to the waveform.

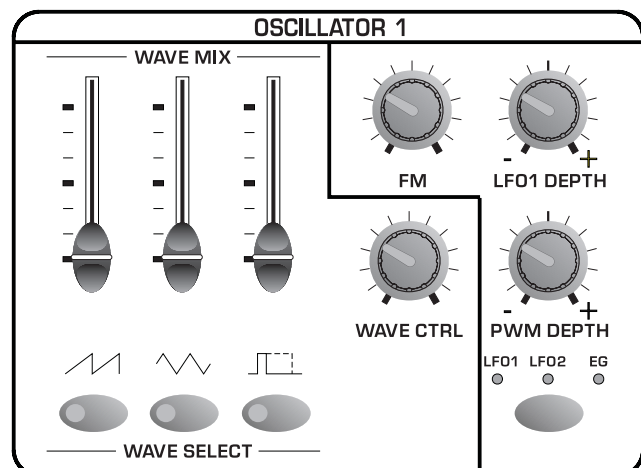

The parameters is:

- Sawtooth wave: modification of the SPREAD parameter
- Triangular wave: modification of the WRAP parameter
- Square wave: modification of the WIDTH parameter

these parameters assume the following functions:

SPREAD: Defines the degree of deformation of the sawtooth waveform. If the parameter is set with values above zero, the sound will be slightly out of tune; this effect will increase as the value becomes higher.

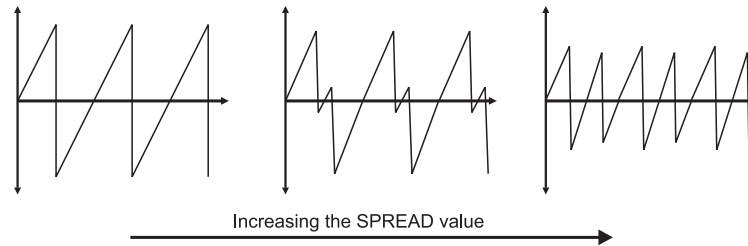

WRAP: Defines the degree of deformation of the triangular waveform. In this case, the greater the deformation, the more overtones are added to the sound generated by the signal.

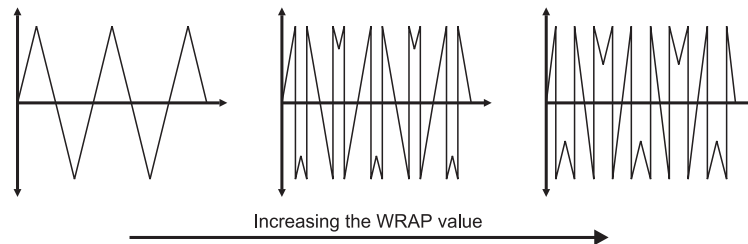

WIDTH: sets the pulse width of the waveform. The trimmer can be turned to the minimum or maximum setting to enrich the harmonic spectrum of the sound.

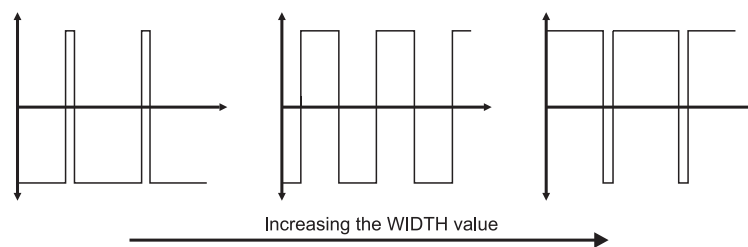

- **[FM]** (*Frequency Modulation*): defines the depth of the frequency modulation of the signal generated by Osc.1 by the signal originating from the second oscillator. As the knob is turned clockwise, the modulation depth increases. The resulting sound will be rich in overtones, suitable for metallic timbres and sound effects.

In addition, you can obtain changes in tone without changing the pitch of Osc.1 by adjusting the [FINE] and [RANGE] trimmers of the OSCILLATOR 2 section.

If the modulation is not noticeable enough, lower the slider [OSC1⇒OSC2] of the OSCILLATOR COMMON section.

- **[LFO1 DEPTH]**: regulates the depth of the frequency modulation by LFO1 (first low frequency oscillator) on the pitch (with cyclic variation) of the Osc.1 signal, thus generating vibrato effects. With the knob turned completely to the right, Osc.1 will be affected by the maximum depth of LFO1 modulation. With the knob in central position, the oscillator will be unaffected by the modulation, and when it is turned completely to the left, the modulation depth will be at the maximum but with opposite phase to that obtained with the knob turned to the right.

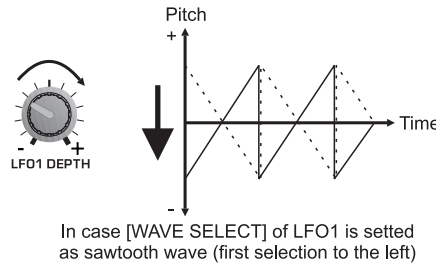

- **[PWM DEPTH]** (*Pulse With Modulation Depth*): this trimmer can be used to regulate the depth of modulation of only the square waveform generated by Osc.1 (and thus not the outcome of the three basic waveforms) by the source specified by means of the button below the trimmer itself. This button allows selection of the following as source of the modulating signal:
 - LFO1: the first low frequency oscillator
 - LFO2: the second low frequency oscillator
 - EG: the envelope generator

The selection will be confirmed by illumination of the corresponding LED.

N.B.: If you have deleted the square waveform (by means of the [WAVE MIX] slider or the [WAVE SELECT] button referred to this signal) you will not be able to hear any acoustic effect generated by this control.

72 SETTING the SECOND WAVEFORM (OSC.2)

As for Oscillator 1, Oscillator 2 also generates the basic waveform of the sound you are creating. Therefore, the two waveforms can be mixed using the BALANCE sliders in the OSC.COMMON section to obtain the most widely varying sound combinations. Since the functions of these two sections are virtually identical, the panel section is also very much the same. As we can see, the controls relating to the second oscillator are:

- **[WAVE MIX]**: you can use these three sliders to mix the three waveforms which will then form the output of the second oscillator. As described on the panel, the first slider controls the level of the sawtooth waveform, the second controls the triangular waveform and the third the square waveform.

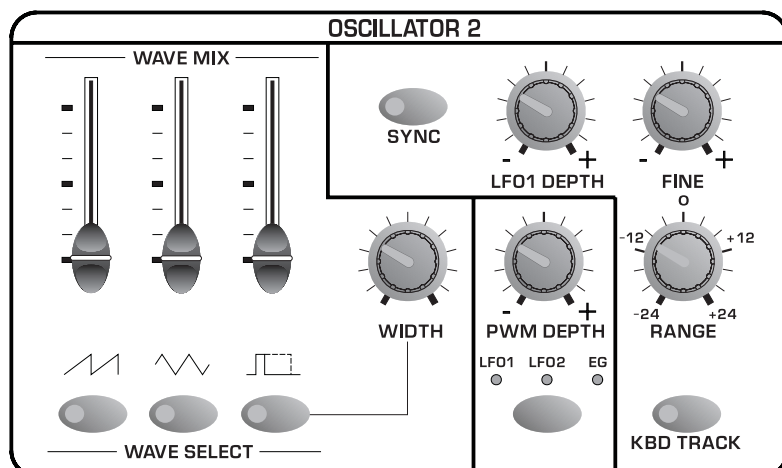

- **[WAVE SELECT]:** you can use these keys to activate/deactivate the waveform associated to them. The LEDs above the keys display the status of the waveform according to the following rule:
 - LED on: waveform present
 - LED off: waveform deactivated
- **[WIDTH]:** this trimmer controls the pulse width of the square waveform. The trimmer can be turned to the minimum or maximum setting to enrich the harmonic spectrum of the sound.
- **[SYNC]** (*Synchronisation*): this button activates (LED on) and/or deactivates (LED off) the synchronisation of the waveform leaving Osc.2 with that generated by Osc.1. This means that whenever the Osc.1 waveform returns to its starting point the Osc.2 waveform will also be reset (or returned to its cycle start). As the diagram below shows, the result is a more complex waveform:

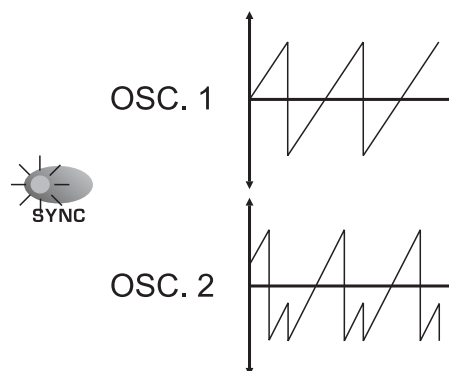

If the synchronisation effect is not very noticeable, increase the first slider on the left [OSC1 \Rightarrow OSC2] in the OSCILLATOR COMMON section.

- **[LFO1 DEPTH]:** regulates the depth of the frequency modulation by the LFO1 (first low frequency oscillator) on the pitch (with cyclic variation) of the Osc.2 signal, thus generating vibrato effects. With the knob turned completely to the right, Osc.2 will be affected by the maximum depth of LFO1 modulation. With the knob in central position, the oscillator will be unaffected by the modulation, and when it is turned completely to the left, the modulation depth will be at the maximum but with opposite phase to that obtained with the knob turned to the right.
- **[FINE]:** regulates the fine tuning of Osc.2 in a range of ± 50 hundredths of a semitone. When the trimmer is in the central position, there is no change in the pitch.
- **[RANGE]:** regulates the tuning of Osc.2 in a range of ± 24 semitones. When the trimmer is in the central position, there is no change in the pitch.

The main feature of these two controls is that they put the second oscillator out of tune with the first. This allows you to generate effects giving space to the sound, and harmonisation between the two oscillators (if the difference in pitch is set, for example, at 5-7 semitones).

- **[PWM DEPTH]** (*Pulse With Modulation Depth*): this trimmer can be used to regulate the depth of modulation of only the square waveform generated by Osc.2 by the source specified by means of the button below the trimmer itself. This button allows selection of the following as source of the modulating signal:
 - LFO1: the first low frequency oscillator

- LFO2: the second low frequency oscillator
- EG: the envelope generator

The selection will be confirmed by illumination of the corresponding LED.

N.B.: If you have deleted the square waveform (by means of the [WAVE MIX] slider or the [WAVE SELECT] button referred to this signal) you will not be able to hear any acoustic effect generated by this control.

- **[KBD TRACK]** (*Keyboard Tracking*): you can use this button to choose between standard use of the keyboard (with the Keyboard Tracking function active), so that each note corresponds to each single key, or with the function disabled, giving generation of the same note regardless of which keyboard note has been pressed. Use the [FINE] and [RANGE] trimmers to regulate the pitch of the signal and thus of the note generated.

The LED will display the status of the function in accordance with the following logic:

- LED on: function active
- LED off: function disabled

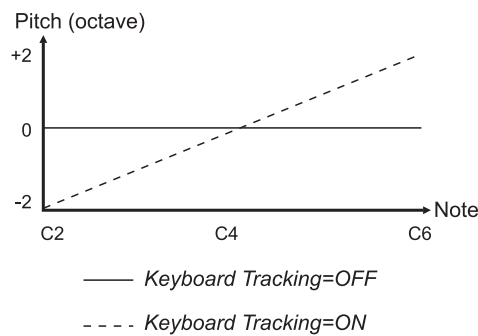

7.3 MODIFYNG the PARAMETERS COMMON TO OSC.1 and OSC.2 (OSC.COMMON)

In this section you can regulate the balancing between the two oscillators, a Ring Modulator and white noise, and specify the envelope of the two oscillators, i.e. how the tuning will change over time.

The Ring Modulator multiplies the two waveforms emitted by Osc.1 and Osc.2 to produce a signal formed by a large number of harmonic and unharmonic partials not present in the original signals. The main feature of the Ring Modulator is that it makes the sound more metallic, dissonant and almost out of tune.

White noise is a wide-band non-periodic signal containing all the frequencies in the audible band, which you can use to add a slight hiss to the original signal. It is useful when simulating sounds containing noises or unharmonic elements.

The OSC.COMMON section containing the following controls:

- **[BALANCE]:** these three sliders regulate the balancing of the oscillators, the Ring Modulator and the Noise in accordance with a clearly defined logic. The first slider on the left regulates the balancing between Osc.1 and Osc.2. With the slider in the lowest position, only the signal received from Osc.1 will be present, while as the slider is raised the amount of signal received from Osc.2 will increase and the proportion of the Osc.1 signal will decrease, until (with the slider completely up) only the signal generated by Osc.2 is present. With the slider in the central position, identical amounts of the Osc.1 and Osc.2 signals will be present. The second